

URBANISTICA, MATERIALI ED EDILIZIA

#ARCHILETTURA

Luigi Pirandello

UNO, NESSUNO
E 1:100000

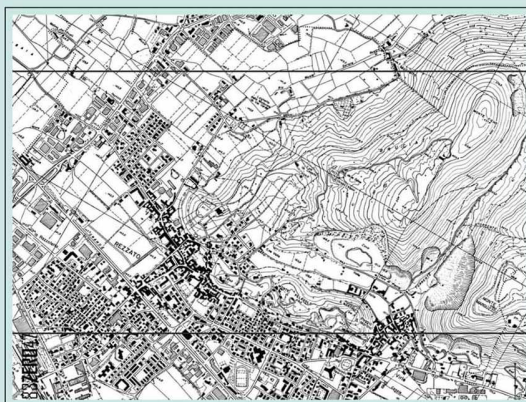

ARCHITETTI
ANONIMI



SCEGLIRE I MATERIALI ADATTI: RESISTENZA DI MATERIALI



I MATERIALI: IL CALCE-STRUZZO



I MATERIALI: LE COSTRUZIONI IN ACCIAIO

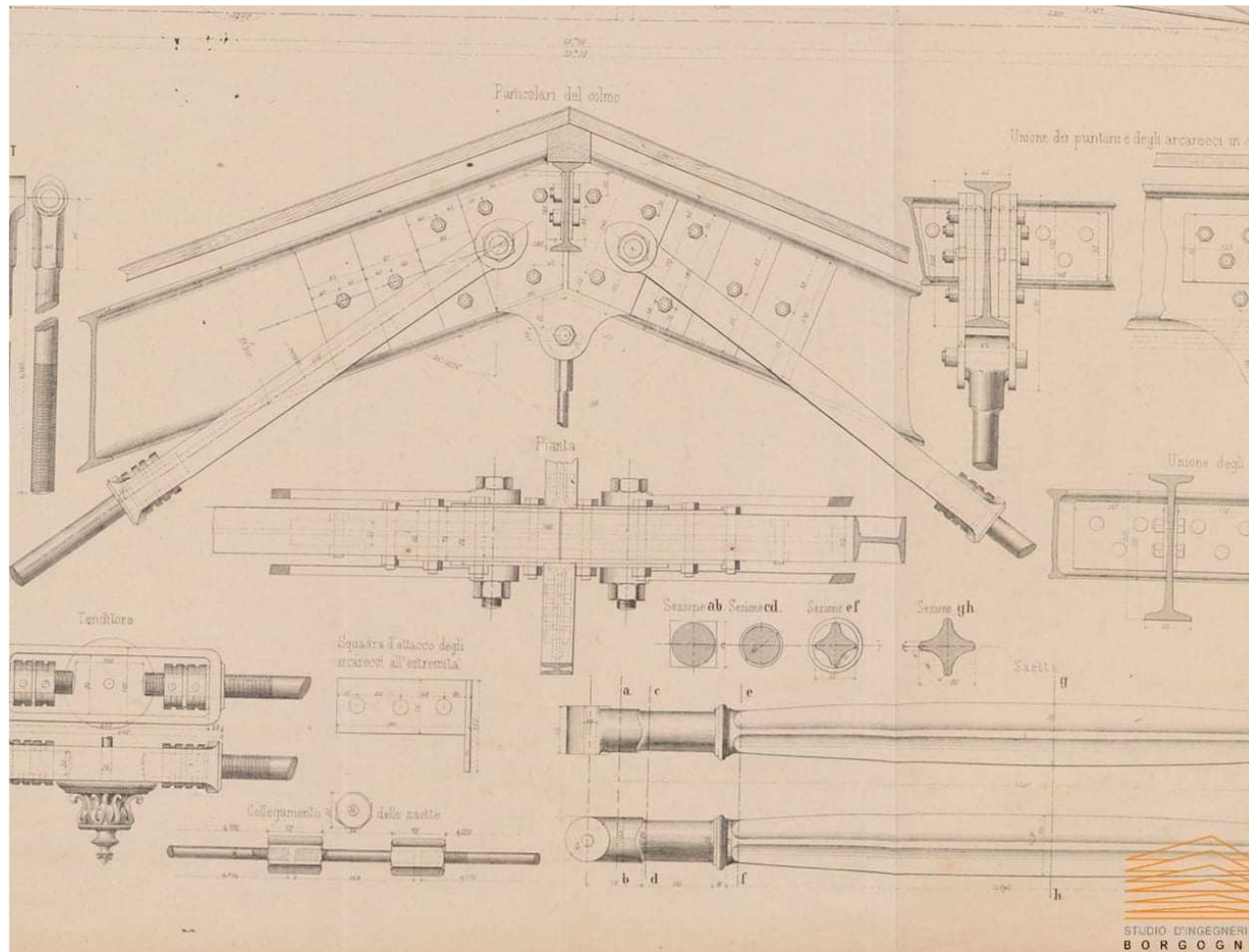

I MATERIALI: LE COSTRUZIONI IN MURATURA

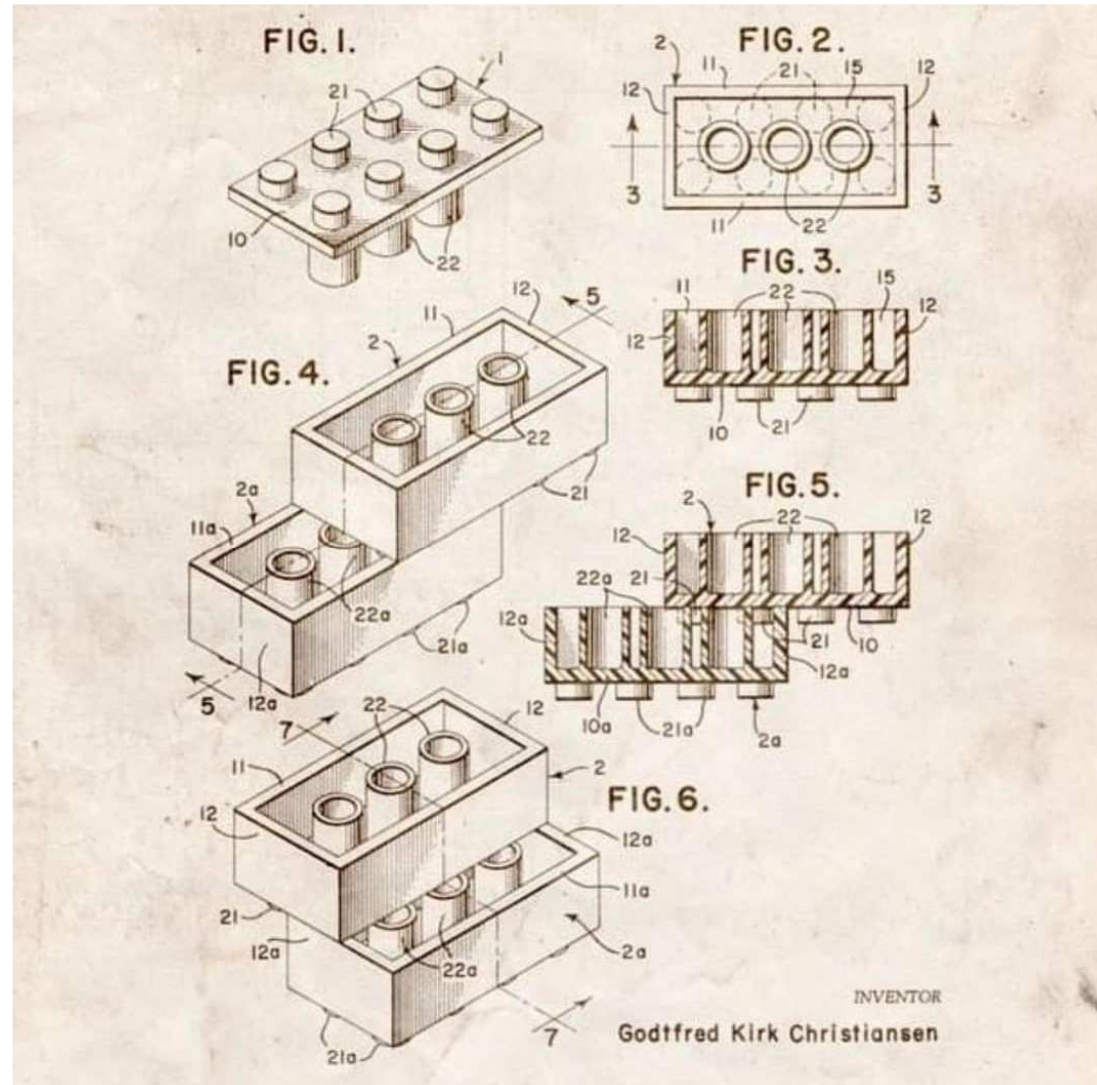

I MATERIALI:

LE COSTRUZIONI IN MURATURA

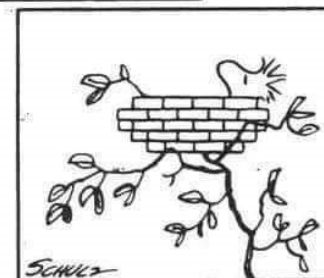

FURONO REALMENTE SALVI? L'ABUSIVISMO EDILIZIO... QUESTO SCONOSCIUTO...



NORMATIVA URBANISTICA E REGOLAMENTI EDILIZI....



IL REGOLAMENTO EDILIZIO: QUESTO SCONOSCIUTO....



LA PROGETTAZIONE DEGLI EDIFICI

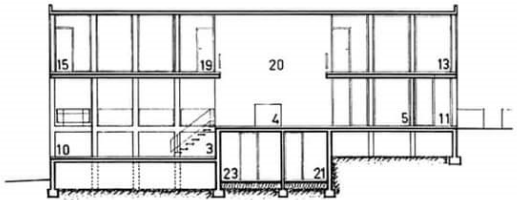
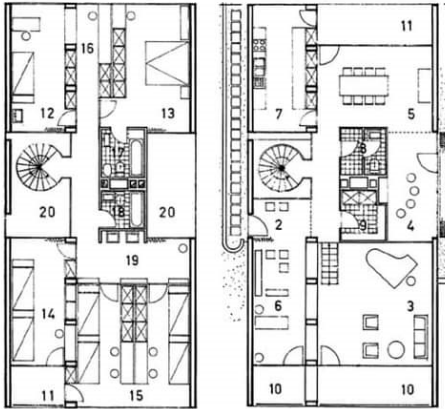
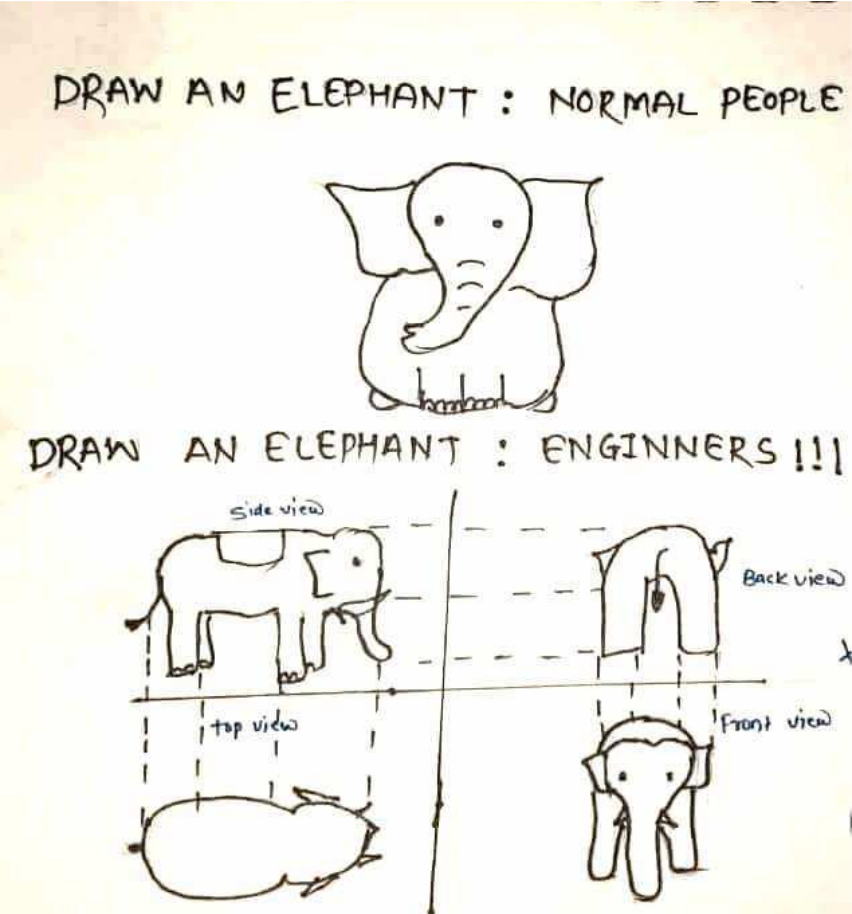

- 2. HALL
- 3. LIVING AREA
- 4. FIREPLACE
- 5. DINING ROOM
- 6. WORKSPACE
- 7. KITCHEN
- 8. WC
- 9. CLOAKROOM
- 10. BALCONY
- 11. PORTICO
- 12. MAID'S ROOM
- 13. MASTER BEDROOM
- 14. BEDROOM (BOYS)
- 15. BEDROOM (GIRLS)
- 16. UTILITY AREA
- 17. BATHROOM (PARENTS)
- 18. BATHROOM (CHILDREN)
- 19. PLAYROOM
- 20. VOID
- 21. ENGINE ROOM
- 23. HEATING ROOM



LA PROGETTAZIONE DEGLI IMPIANTI



UN MARE DI PROGETTI...

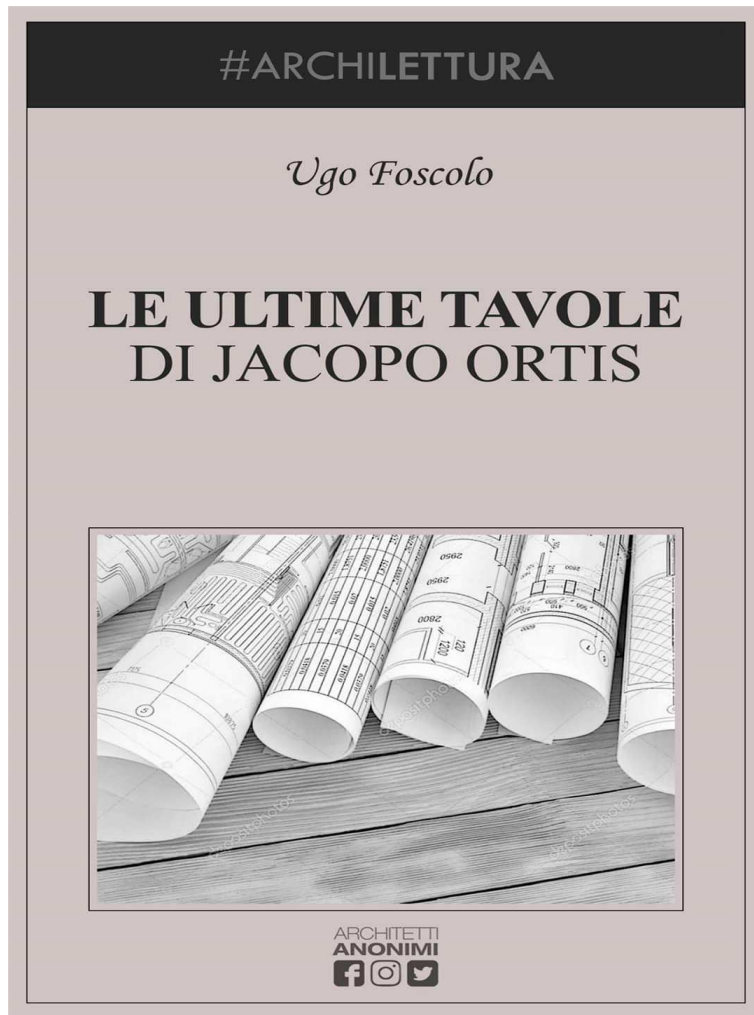

IL COMMITTENTE DELLE OPERE...



L'INGEGNERE



INGEGNERE

tariffa oraria

- Standard..... 50€
- Se hai già un "disegnino"..... 100€
- Se hai il cugino geometra..... 150€
- Se ti senti un pò architetto..... 200€
- Se vuoi insegnarmi il mestiere.. 250€
- Se mi chiedi lo sconto..... 300€

DISORDINE DEGLI ARCHITETTI

L'ARCHITETTO



Arch.: "ho pensato di fare delle travi a sbalzo di 7 m, non vedo problemi"

Ing.:

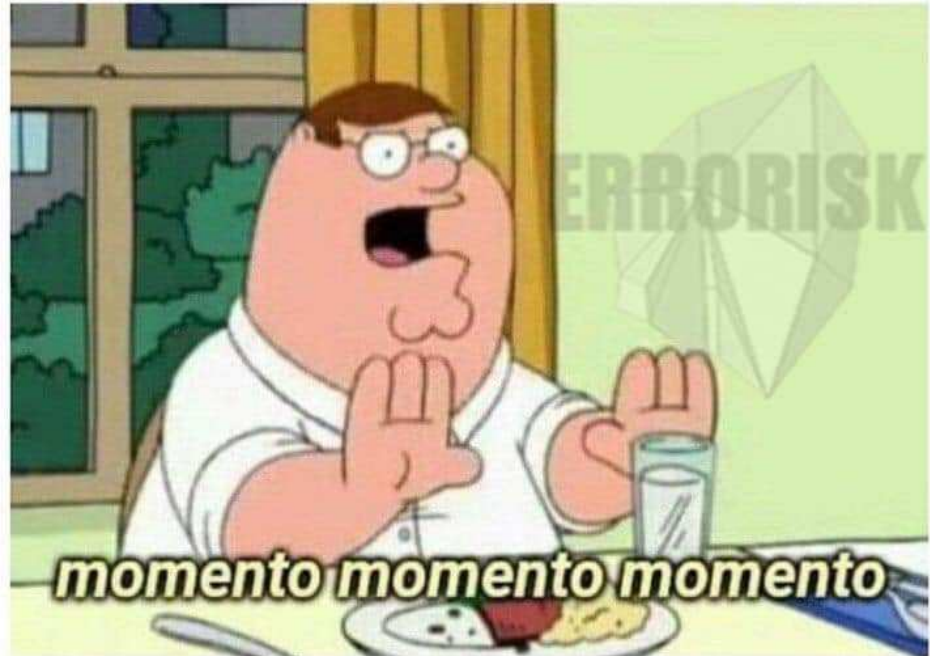

IL GEOMETRA



IL CANTIERE E LA SICUREZZA SUI LUOGHI DI LAVORO

#ARCHILETTURA

Harper Lee

IL CANTIERE OLTRE LA SIEPE



ARCHITETTI
ANONIMI
f i t



IL CANTIERE E LA SICUREZZA: I CONTROLLI



IL CANTIERE E LA SICUREZZA: I CONTROLLI



IL CANTIERE E L'ESECUZIONE DELLE OPERE



GRAZIE PER L'ATTENZIONE



www.tecnologiaedisegno.altervista.org